

## CLIMB2

DUAL MONITOR SIT/STAND WORKSTATION

Model CLIMB2-SLV

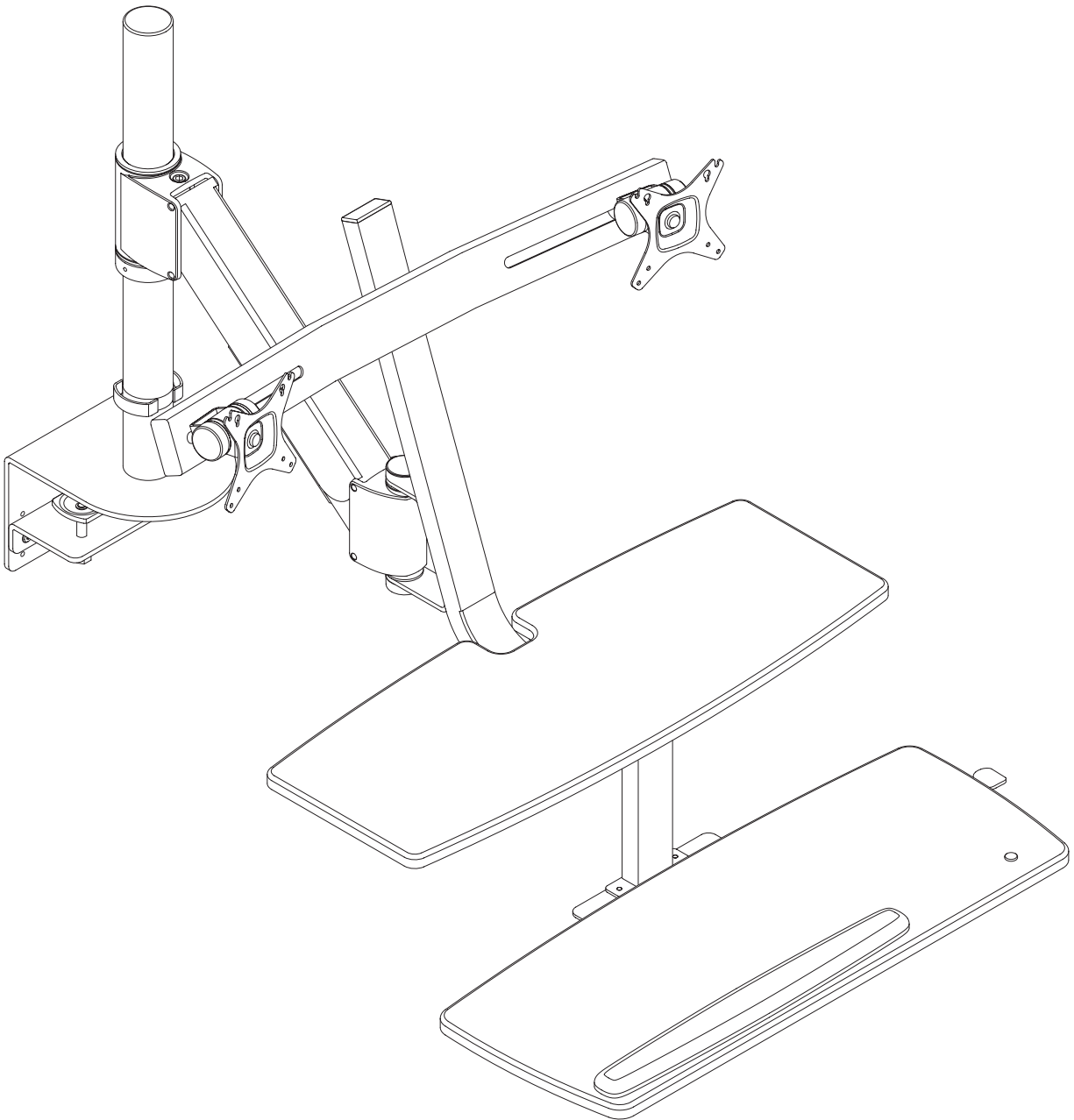





CLIMB2 Rev A 3/17

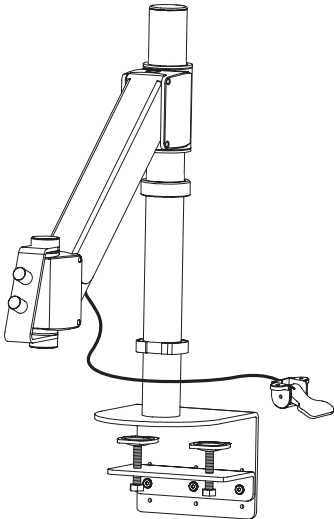
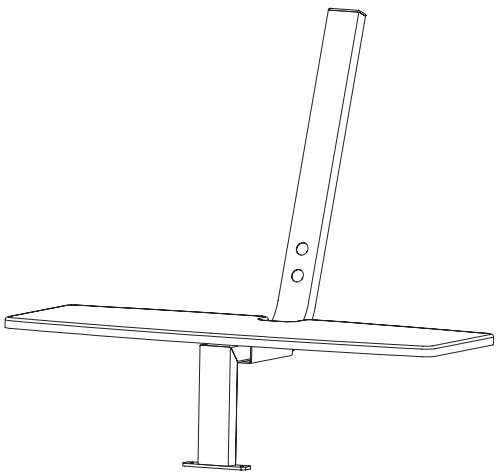
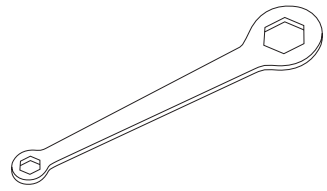
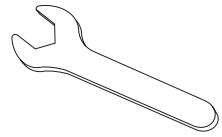
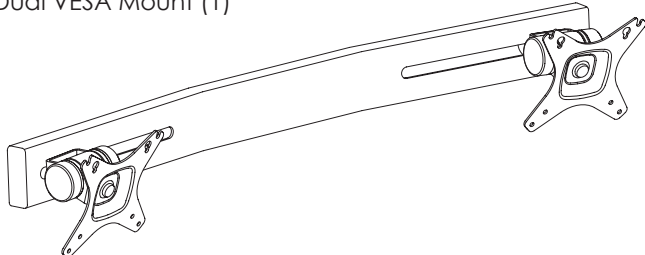
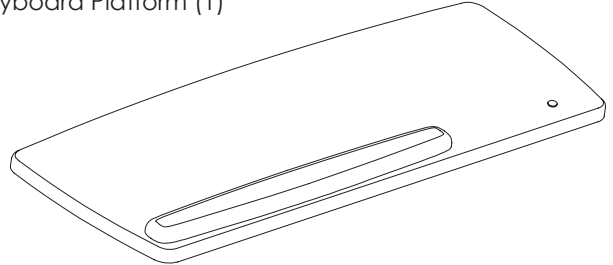

# ASSEMBLY AND ADJUSTMENT

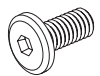
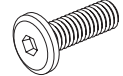
**PLEASE REVIEW** these instructions before beginning the assembly and adjustment procedures. Check that all the parts and tools listed below were provided with your order. Contact your supplier if any materials are missing. Do not discard the packaging until satisfied that the product operates to your satisfaction.

**PARTS AND TOOLS PROVIDED**

<p>Base and Column Assembly (1)</p> 	<p>Writing Platform Assembly (1)</p> 	<p>1/2" Socket Wrench (2)</p>  <p>5/8" Wrench (1)</p> 	
<p>Dual VESA Mount (1)</p> 	<p>Keyboard Platform (1)</p> 		
<p>Nut (2)</p> 	<p>Star Washer (2)</p> 	<p>M6x10mm Screw (2)</p> 	<p>M6x15mm Screw (2)</p> 
<p>M4x12mm Screw (8)</p> 	<p>Keyboard Hole Plug (2)</p> 	<p>Allen Keys (1 each)</p> 	

**CAUTION:** Hand-tighten screws only. Do **not** use power tools.

**ADDITIONAL TOOLS REQUIRED**

- Phillips screwdriver

## Clamp Base and Column Assembly to Work Surface

The base clamp requires 4" of clearance under the work surface for attachment. The clamp accommodates work surface thicknesses from 3/4" to 3.3" (20mm to 80mm).

### Adjust Clamp, If Necessary

- The clamp as shipped can be attached to work surfaces from 1 3/4" to 3.3" thick.
- For thinner work surface thicknesses, the three screws on the clamp portion may be removed and the clamp re-attached in one of the other three sets of holes. Each set of holes is approximately 1" apart.

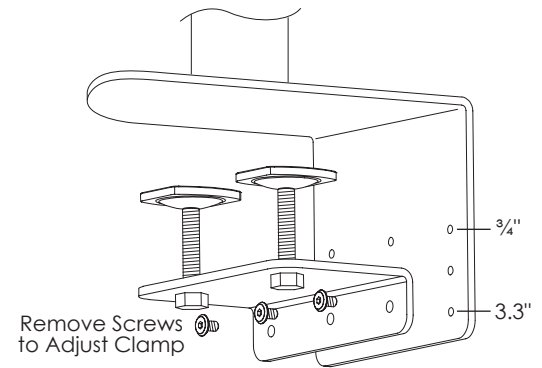

### Attach Clamp

- Position the clamp at the desired location, with the back of the clamp flush against the back of the work surface.
- Use the provided 5/8" wrench to tighten the clamp bolts.

**IMPORTANT:** Be sure the clamp is securely tightened.

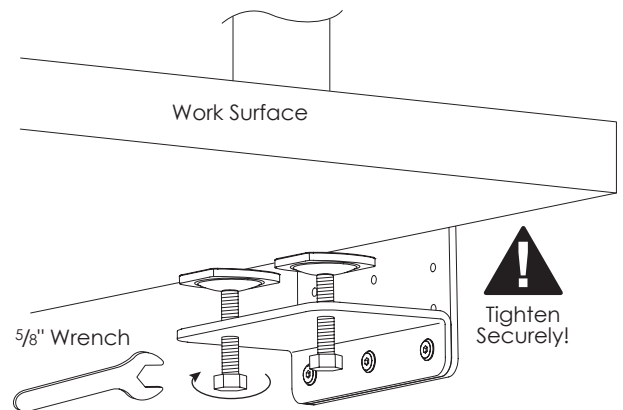

### Adjust Height of Main Assembly Arm

**TIP:** It is beneficial to have a helper to support the main assembly arm when making this adjustment.

- Use the 3mm Allen key to loosen the two set screws in the locking ring.
- Move the locking ring up or down to set the height of the main assembly arm. The main assembly arm rests on top of the locking ring.
- Tighten the two set screws to secure the locking ring/main assembly arm in the desired position.
  - This adjustment can be fine-tuned at any time. It is especially important to have a helper hold the main assembly arm after the monitor, keyboard, etc. are in position.

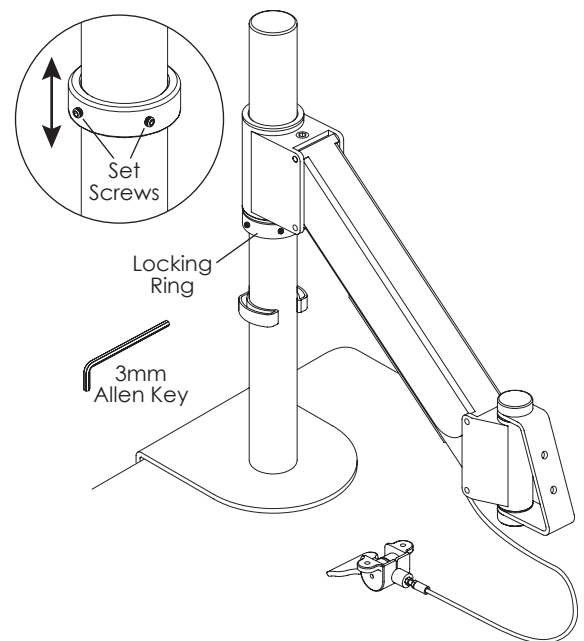

**WARNING:** Do not engage the paddle until after assembly is complete. With no load on it, the main assembly arm could raise quickly and suddenly.

### **Attach Writing Platform to Main Assembly Arm**

- Insert the threaded bolts on the writing platform through the holes on the mount at the end of the main assembly arm.
  - Secure the bolts using the nuts and star washers provided, as shown. Tighten the nuts using the ½" socket wrench.
- Be sure the flat side of the nut is against the star washer.

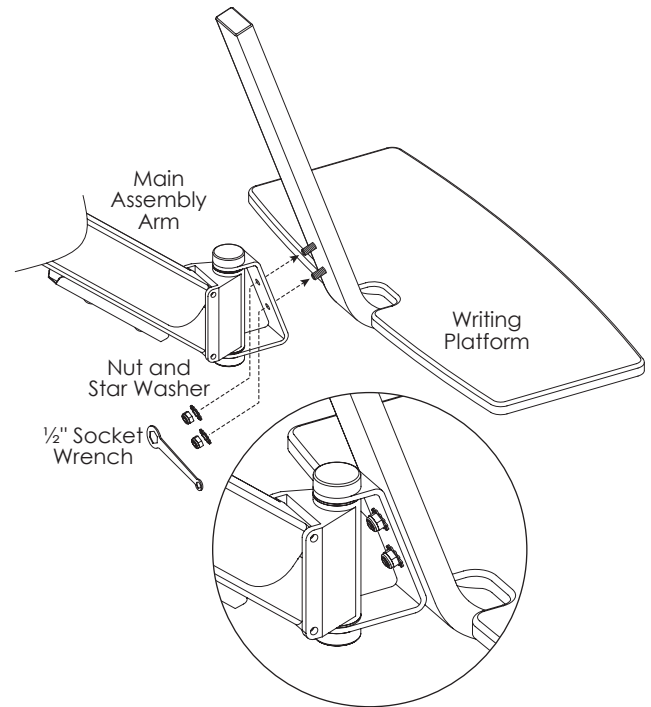

### **Change Side of Keyboard Palm Rest, If Desired**

By default, the keyboard palm rest is on the left side for a right-side mouse. If desired, it may be changed to the right side for a left-side mouse.

- Using the 4mm Allen key, remove the screws holding the palm rest from the underside of the keyboard platform. Remove the plug from the far right-side hole.
- Re-install the screws to attach the palm rest to the right side of the keyboard platform. Use one of the new plugs provided to conceal the exposed left-side hole.

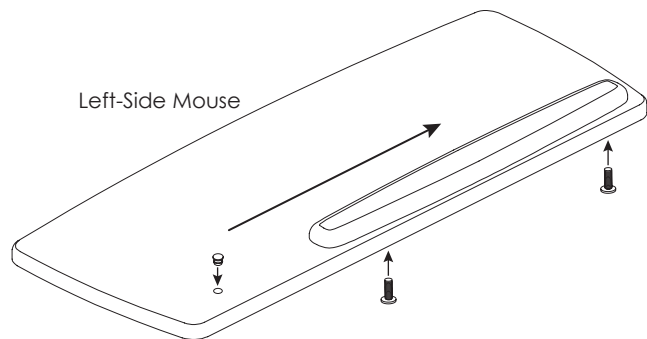
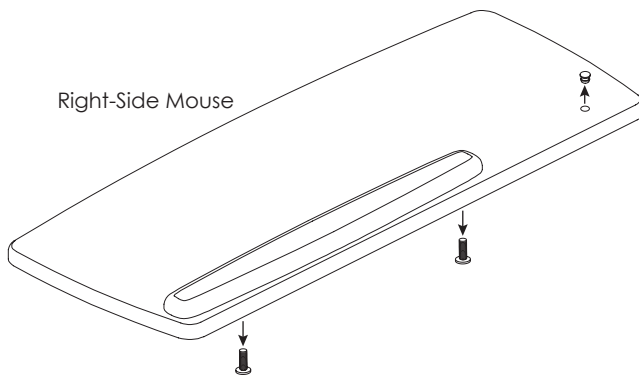

### **Attach the Paddle to the Keyboard Platform**

By default, the paddle is attached to the right side of the keyboard platform, where there are two holes for the M6x15 screws. If desired, the two screws on the left side of the platform may be moved to the right side so that the paddle can be attached on the left side.

- Use the 4mm Allen key to secure the paddle on the left or right side with the M6x15 screws.

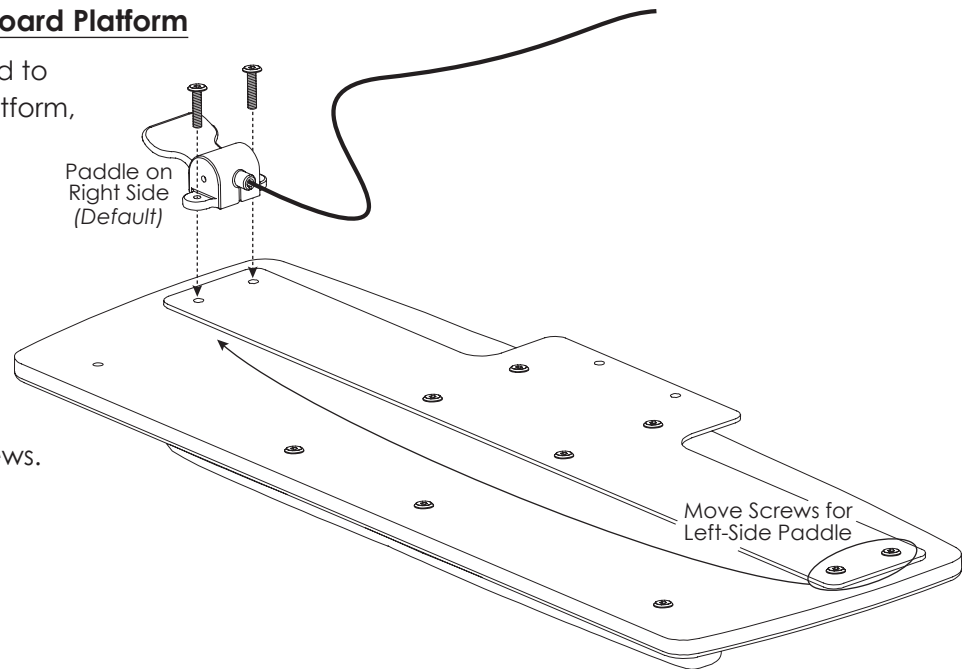

### **Attach the Keyboard Platform**

- Using the 4mm Allen key, attach the keyboard platform with two M6x8 screws, as shown. Tighten securely.
- After attaching the keyboard platform, route the paddle cable through the clips on the underside of the writing platform.

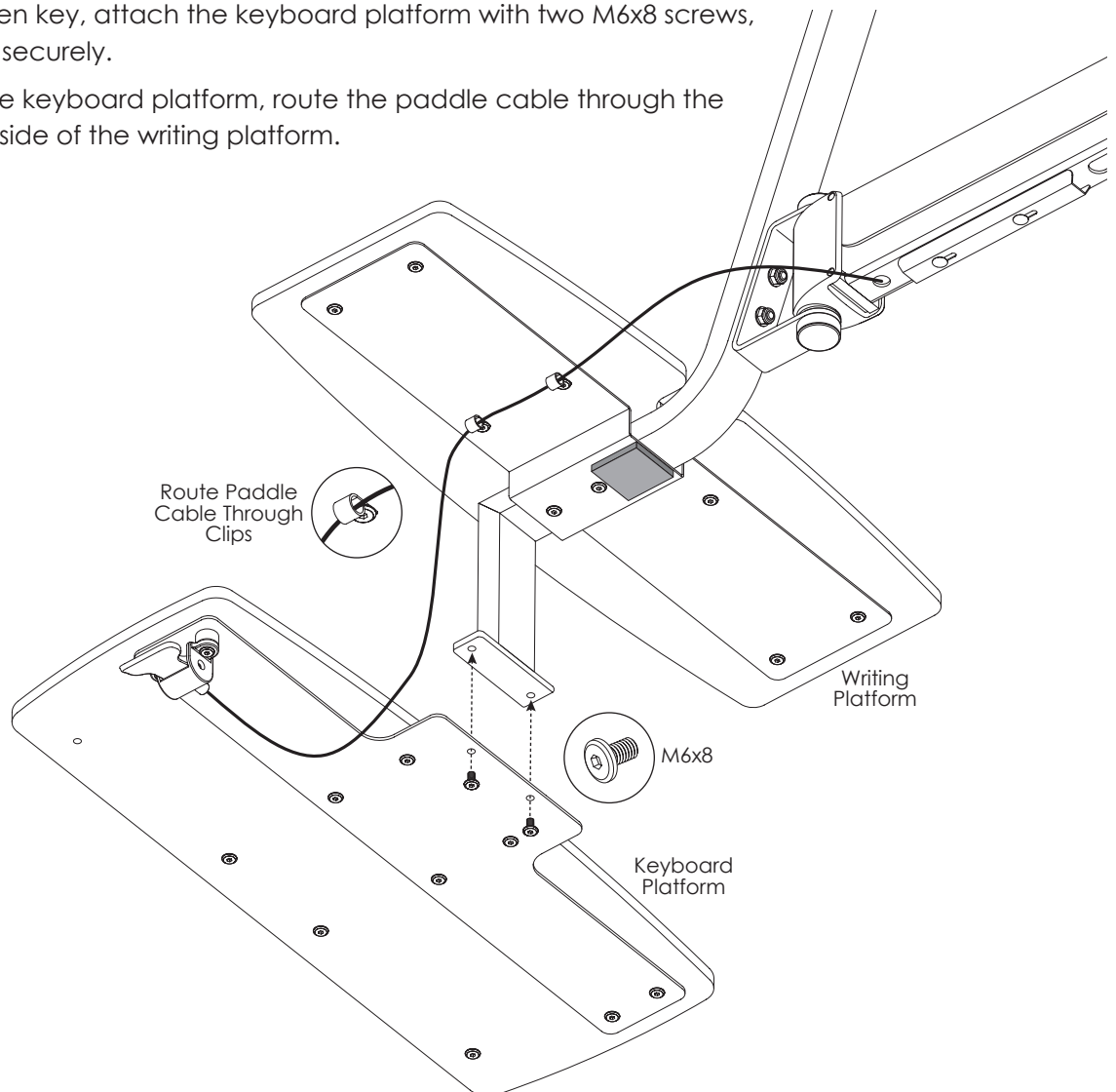

### **Attach Dual VESA Mount to Writing Platform Column**

- Loosen the knobs on each side of the dual VESA mount to allow the mount to fit over the writing platform column.
- With the open slots on top, slide the dual VESA mount over the column and position at the desired height. Tighten the knobs.
- The height of the VESA mount may be adjusted at any time by loosening the knobs.

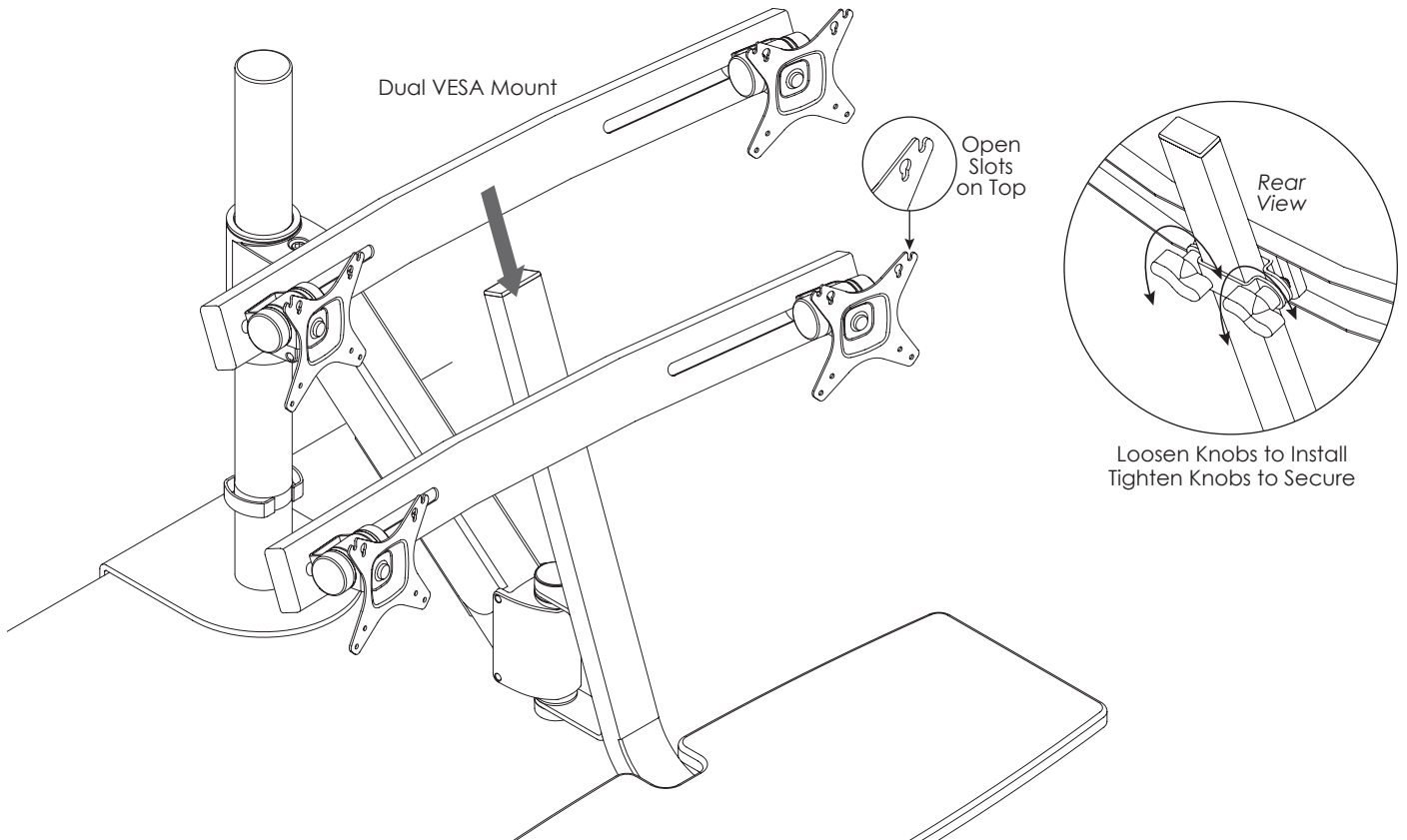

### **Attach VESA Screws to Monitor**

- Place the monitor face down on a flat surface.
- Use the 3mm Allen key to attach M4x12 VESA screws into the top two holes only.
- Do not tighten the screws all they way. Leave 1/4" exposed for attachment to the VESA mount.

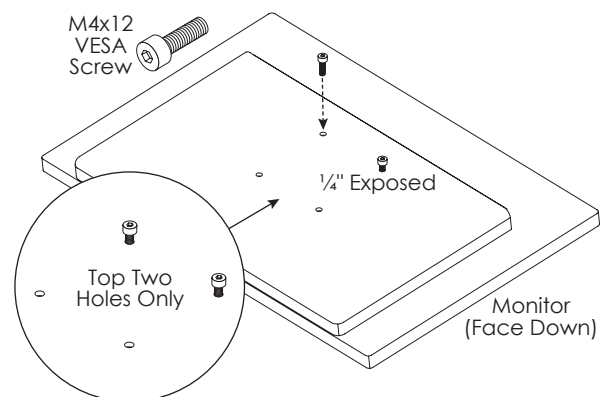

### **Attach Monitors to VESA Mounts**

- Hang the monitors on the VESA mounts.
  - If the outer set of VESA holes was used (100mm apart), hang the two top screws in the open slots.
  - If the inner set of holes was used (75mm apart), insert the two screw heads through the top inner holes and hang the monitor from those screws.
- Attach the bottom of the VESA mounts using the remaining M4x12 screws and the 3mm Allen key.
- Tighten all screws securely.

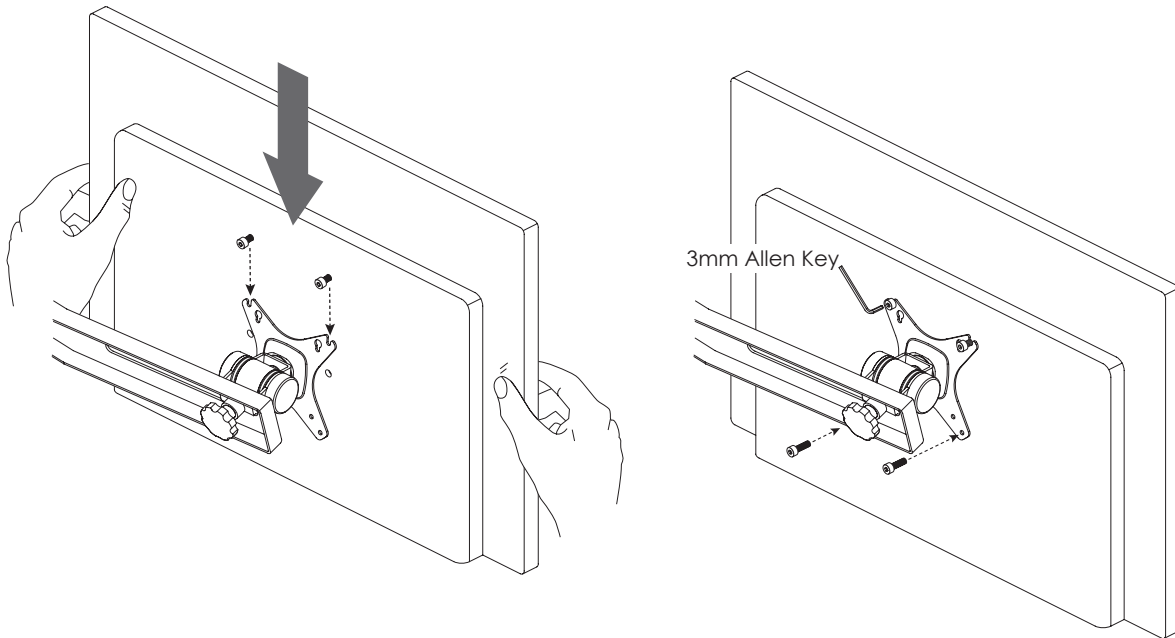

### **Cable Management**

After positioning the keyboard and mouse, organize the cables. Cables must not interfere with product operation or with the user's ergonomic enjoyment of the unit.

- Remove the cable cover using a Phillips screwdriver.
- Re-install the cable cover with the monitor and keyboard cables captured.
- Use the pole clip to route the cables down to the CPU or power outlet.

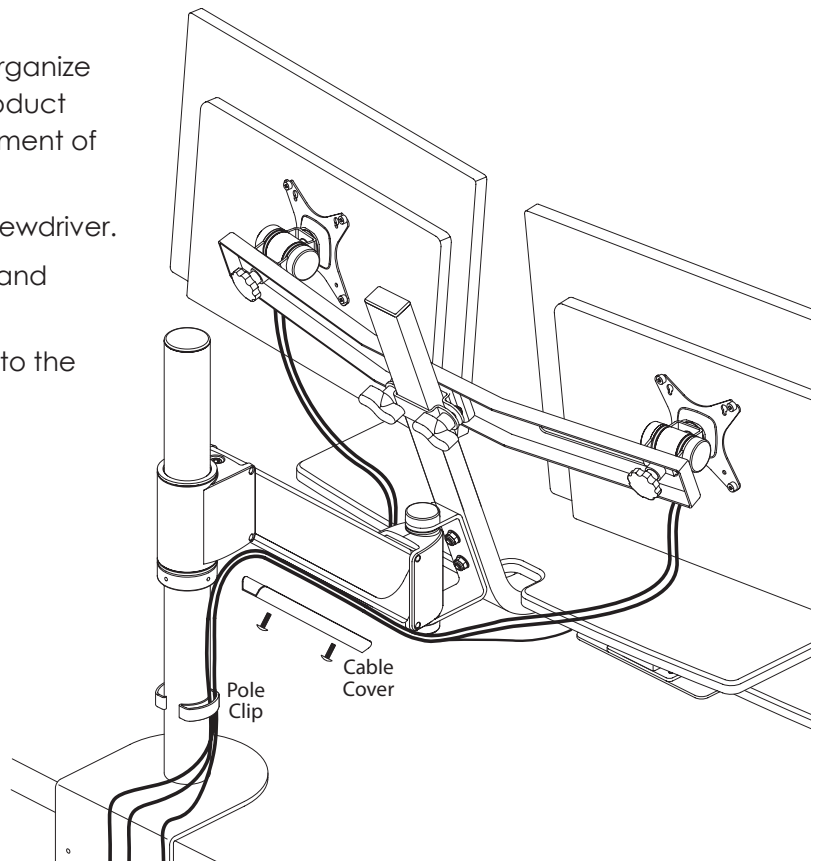

### Adjust Angle of Monitors, If Necessary

- Remove the plastic caps from the sides of the VESA mount to allow access to the bolt and nut.
- Use the ½" socket wrench to loosen the bolt and nut (counterclockwise). Tilt the VESA mount and monitor to the desired viewing angle.
- After the adjustment is complete, tighten the bolt and nut with the socket wrench (clockwise). Replace the caps.

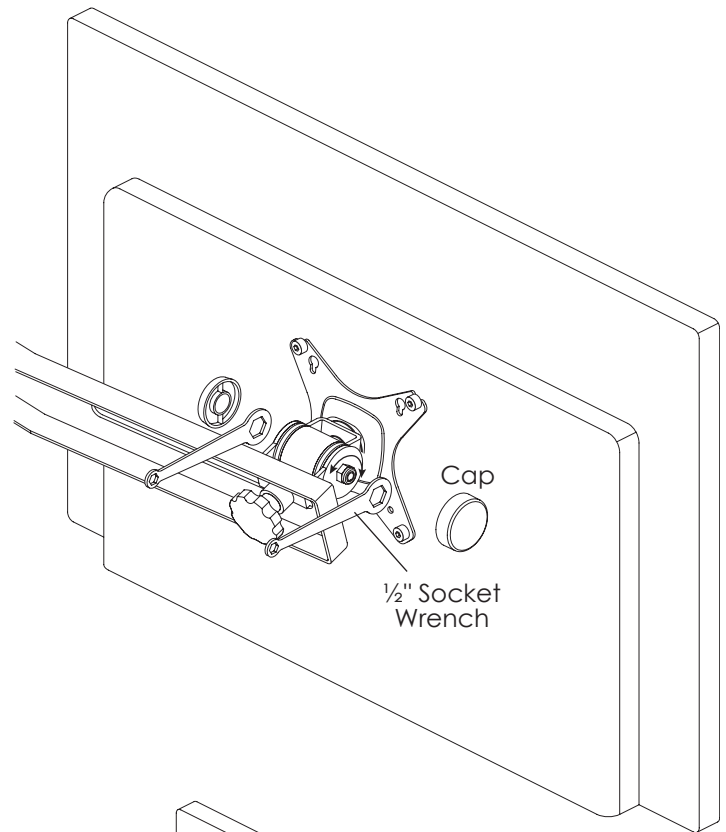

### Adjust Position of Monitors, If Necessary

- The slots in the dual VESA mount allow for approximately 7½" of side-to-side adjustment for each monitor.
- Loosen the knob on the rear of each VESA mount to enable side-to-side movement.
- Tighten the knob securely to hold the VESA mount and monitor in the desired position.

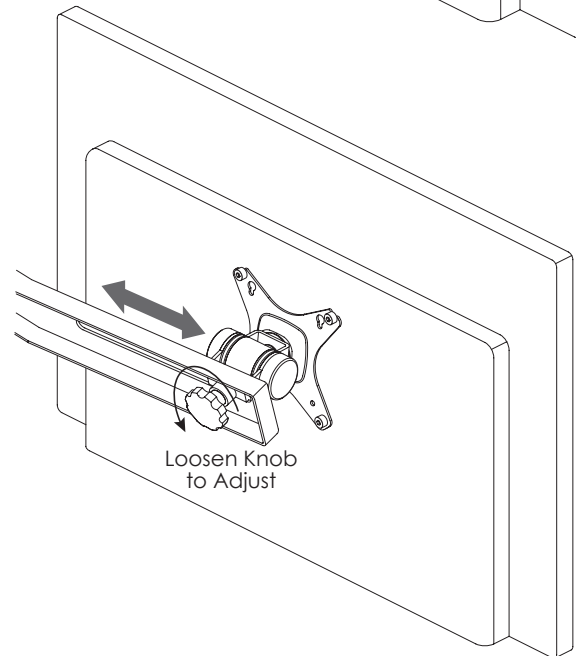

### Test Operation

- Depress the paddle lever. Raise and lower the unit through its full range of movement.
- Position the unit so the column is at a 90° angle. If necessary to fine tune operation of the product, make one or both of the adjustments shown on page 9.

**CAUTION:** Keep both hands on the keyboard platform to control the rate of movement when depressing the paddle lever.



**If Necessary, Adjust for Load Weight**

This adjustment can be used to maximize ease of operation. When operating this product, the main assembly arm should move easily to any position and hold that position.

- If the arm is difficult to raise or lowers too easily, increase the load adjustment (+).
- If the arm is difficult to lower or raises too easily, decrease the load adjustment (-).
- Use the 6mm Allen key to turn the adjusting screw — counterclockwise to increase load, clockwise to decrease it.
- Test operation and re-adjust as necessary.

**CAUTION:** Do not over-tension the MAX (+) adjustment.

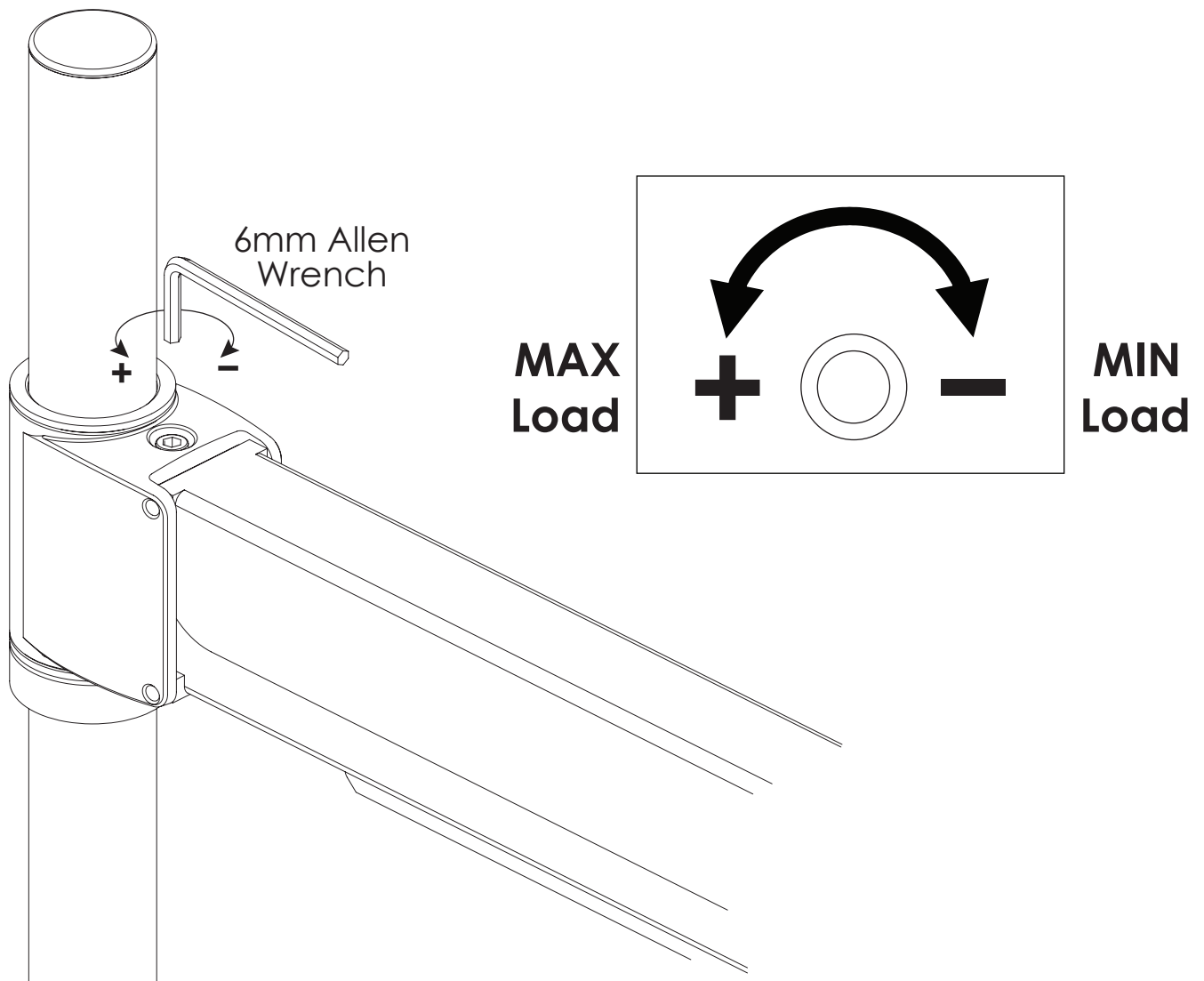



800.833.3746 | [esiergo.com](http://esiergo.com)